

LOW EAVE

- BA0010 - LOW EAVE STRUT FLUSH_INSET SW GIRT AT INTERIOR FRAME 2 BOLT
 - BA0020 - LOW EAVE STRUT BYPASS SW GIRT AT INTERIOR FRAME 2 BOLT
 - BA0025 - LOW EAVE STRUT TERMINATION BYPASS SW GIRT 2 BOLT
 - BA0030 - LOW EAVE STRUT BYPASS SW 2 BOLT
 - BA0040 - LOW EAVE STRUT FLUSH_INSET SW GIRT AT ENDWALL FRAME 2 BOLT
 - BA0050 - LOW EAVE STRUT CF EW 2 BOLT
 - BA0060 - LOW EAVE STRUT FLUSH_INSET SW GIRT WITH STRUT PLATE 4 BOLT
 - BA0070 - LOW EAVE STRUT BYPASS SW GIRT WITH STRUT PLATE 4 BOLT
 - BA0080 - LOW EAVE STRUT BYPASS SW GIRT AT ENDWALL FRAME 4 BOLT
 - BA0090 - LOW EAVE FLUSH_INSET SW GIRT AT RIGID FRAME ENDWALL 4 BOLT
 - BA0100 - LOW EAVE STRUT CF EW 4 BOLT
 - BA0115 - LOW EAVE STRUT FLUSH_INSET AT COLUMN AND ROOF JOIST DETAIL
 - BA0125 - LOW EAVE STRUT AT ENDWALL RAFTER WITH ROOF JOISTS DETAIL
 - BA0140 - CEE PURLIN CONNECTION AT CANOPY
 - BA0145 - CEE PURLIN TERMINATION AT CANOPY
 - BA0200 - EAVE STRUT AT STRUCTURAL EXPANSION DETAIL
 - BA0340 - EAVE ANGLE ATTACHMENT
 - BA0360-EAVE ANGLE ATTACHMENT - JOIST
 - BA2000 - EAVE ZEE MEMBER FOR R-Boost™
-

BA0010 - LOW EAVE STRUT FLUSH/INSET SW GIRT AT INTERIOR FRAME DETAIL

[Download the DWG file by clicking here.](#)

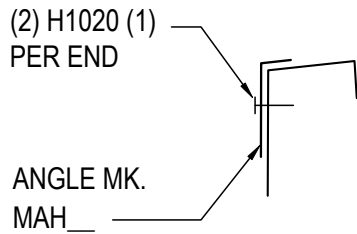

SEC. A

PART	ROOF SLOPE
MAH01	1:12
MAH02	2:12
MAH03	3:12
MAH04	4:12

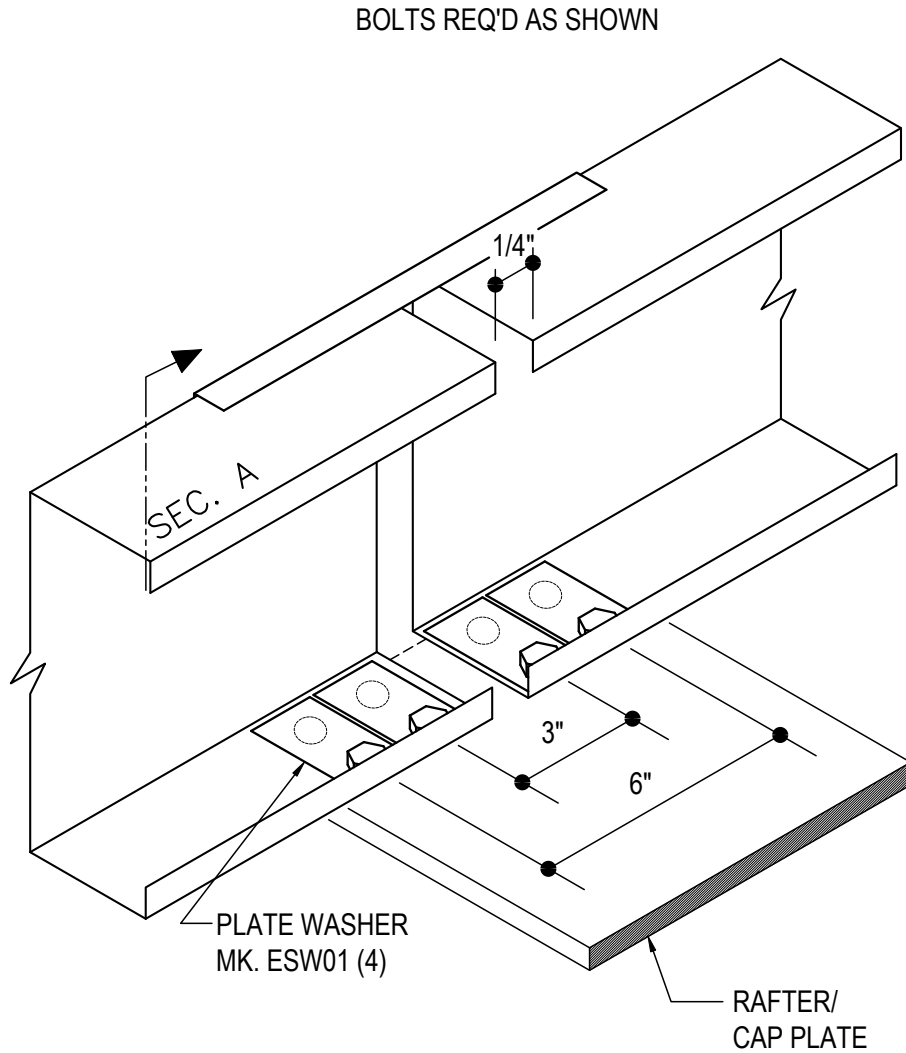

EAVE STRUT AT INTERIOR FRAME

LOW EAVE FLUSH/INSET SW GIRT CONDITION
USE (4) 1/2" X 2" A325 BOLT H0603/NUT H0300 U.N.O.

BA0010

Detailer Notes:

- 1) 8" MIN. CAP PLATE

BA0020 - LOW EAVE STRUT BYPASS SW GIRT AT INTERIOR FRAME DETAIL

[Download the DWG file by clicking here.](#)

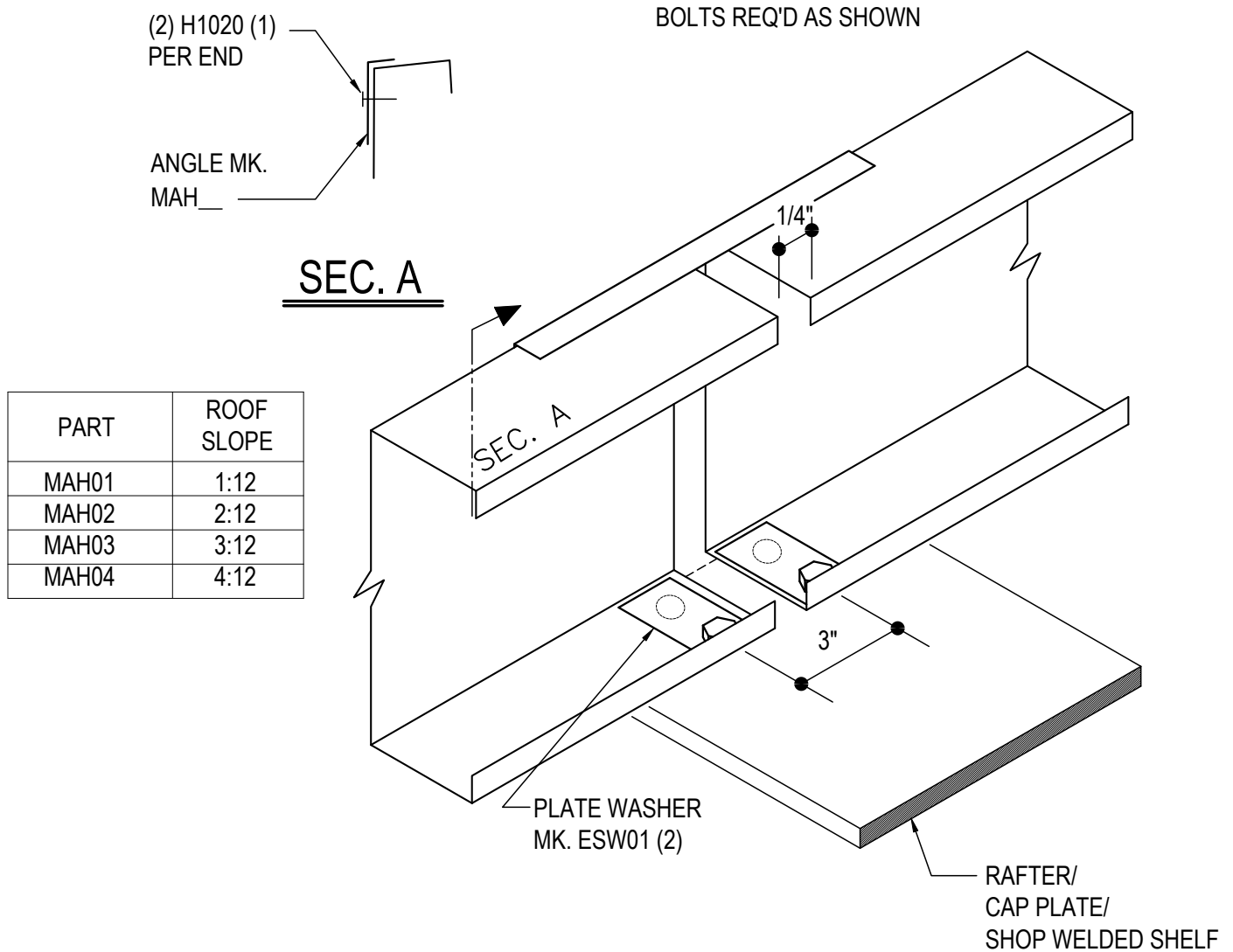

EAVE STRUT AT INTERIOR FRAME

LOW EAVE BYPASS SW GIRT CONDITION
USE (4) 1/2" X 2" A325 BOLT H0603/NUT H0300 U.N.O.

BA0020

Detailer Notes:

1) N/A

BA0025 - LOW EAVE STRUT TERMINATION BYPASS SW GIRT DETAIL

[Download the DWG file by clicking here.](#)

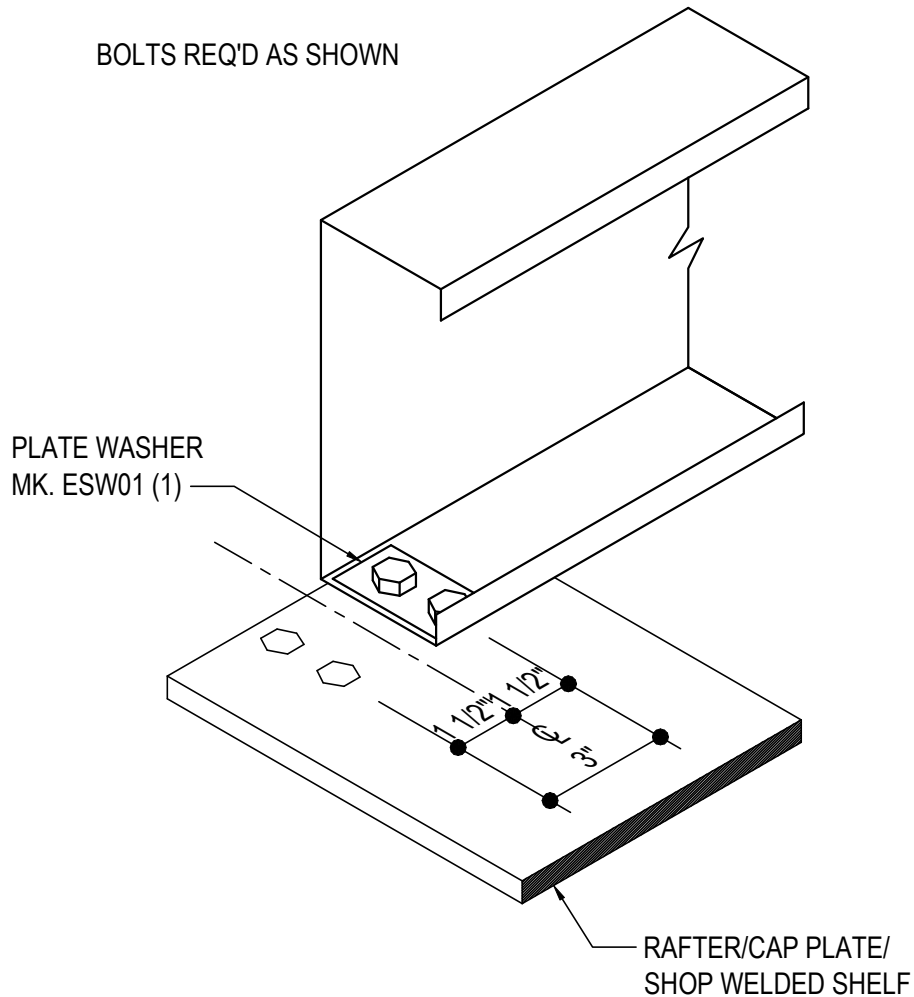

EAVE STRUT TERMINATION

LOW EAVE BYPASS SW GIRT CONDITION
USE (2) 1/2" X 2" A325 BOLT H0603/NUT H0300 U.N.O.

BA0025

Detailer Notes:

1) N/A

BA0030 - LOW EAVE STRUT BYPASS SW DETAIL

[Download the DWG file by clicking here.](#)

BOLTS REQ'D ONLY AS SHOWN

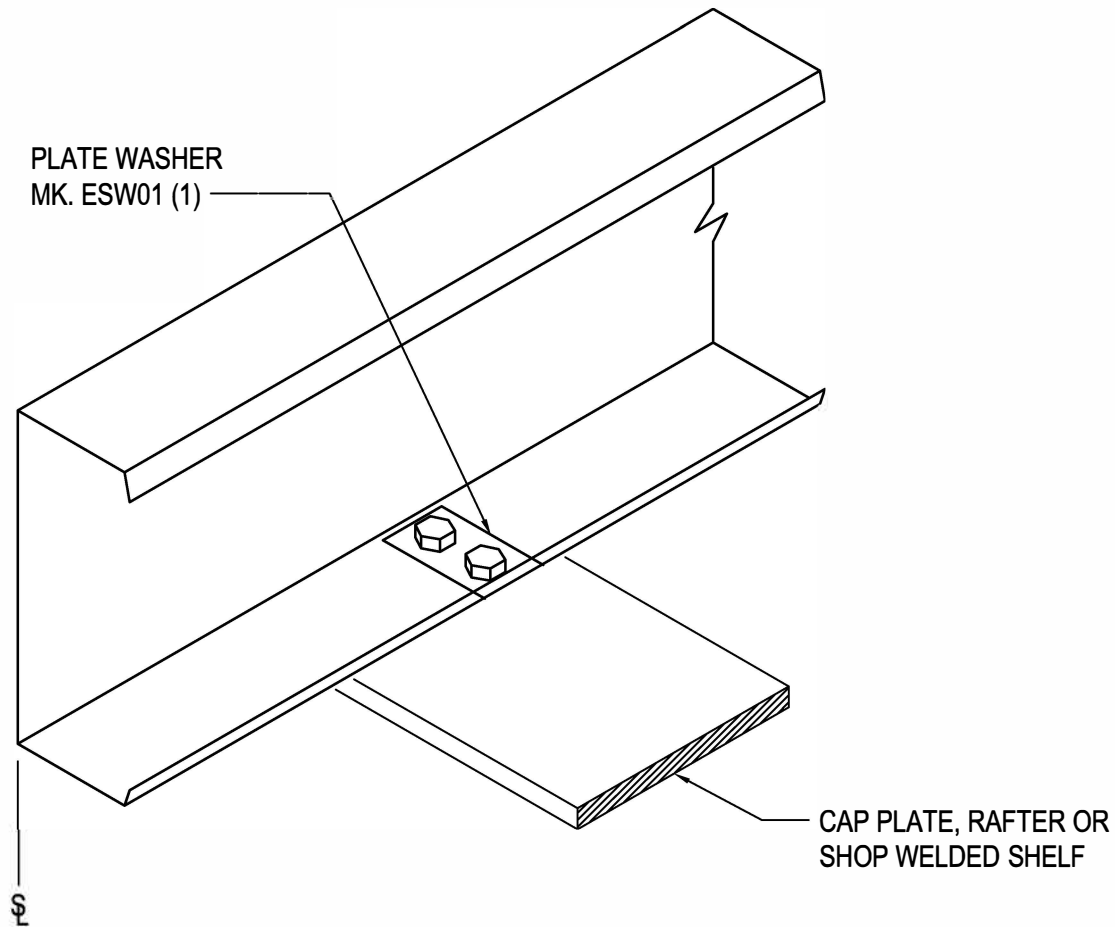

EAVE STRUT

BYPASS SIDEWALL CONDITION

USE (2) 1/2" x 2" A325 BOLT H0603/NUT H0300 U.N.O.

BA0030

Detailer Notes:

1) N/A

BA0040 - LOW EAVE STRUT FLUSH/INSET SW GIRT AT ENDWALL FRAME DETAIL

[Download the DWG file by clicking here.](#)

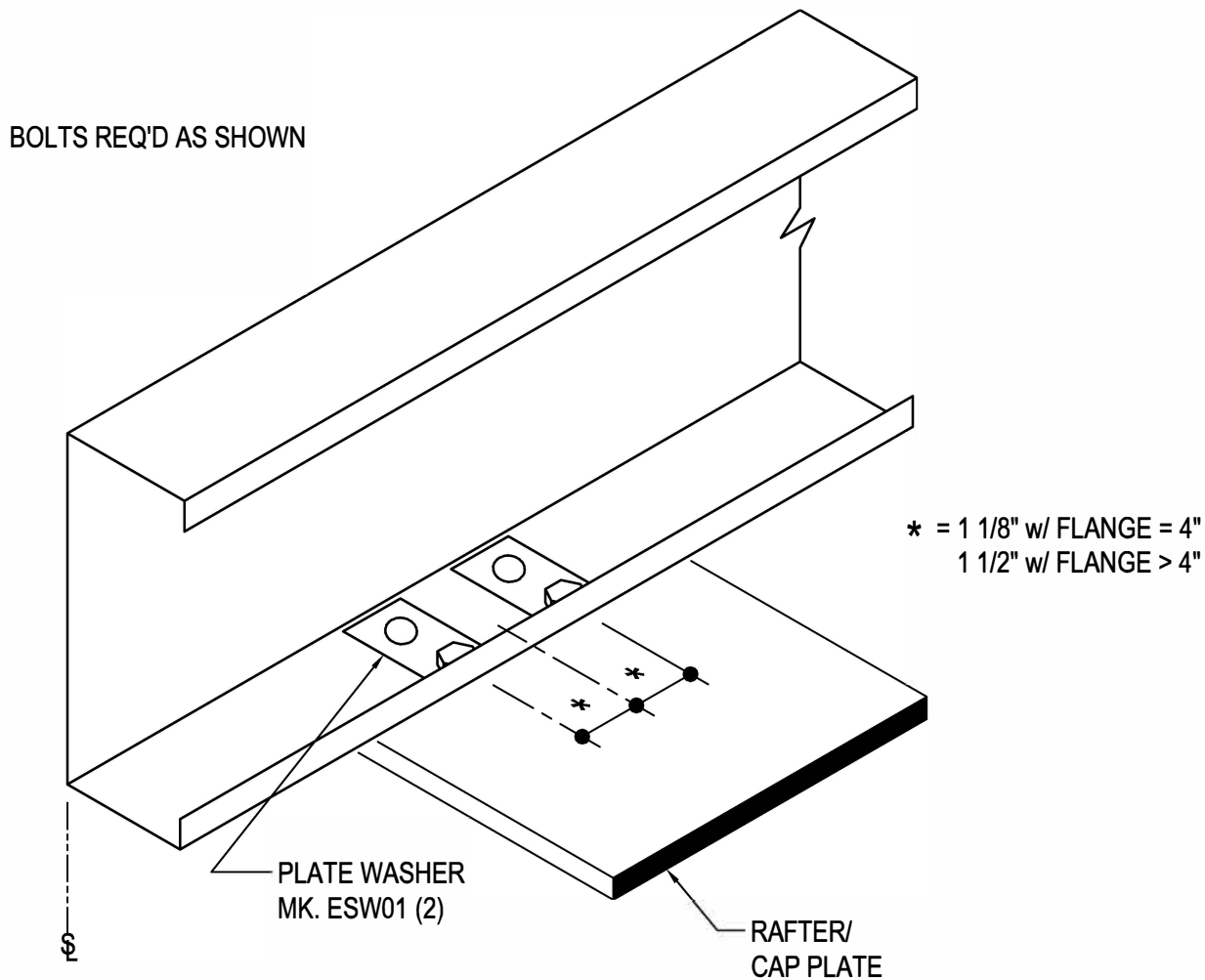

EAVE STRUT AT ENDWALL FRAME

LOW EAVE - FLUSH/INSET SW GIRT CONDITION
USE (2) 1/2" x 2" A325 BOLT H0603/NUT H0300 U.N.O.

BA0040

Detailer Notes:

- 1) N/A

BA0050 - LOW EAVE STRUT CF EW DETAIL

[Download the DWG file by clicking here.](#)

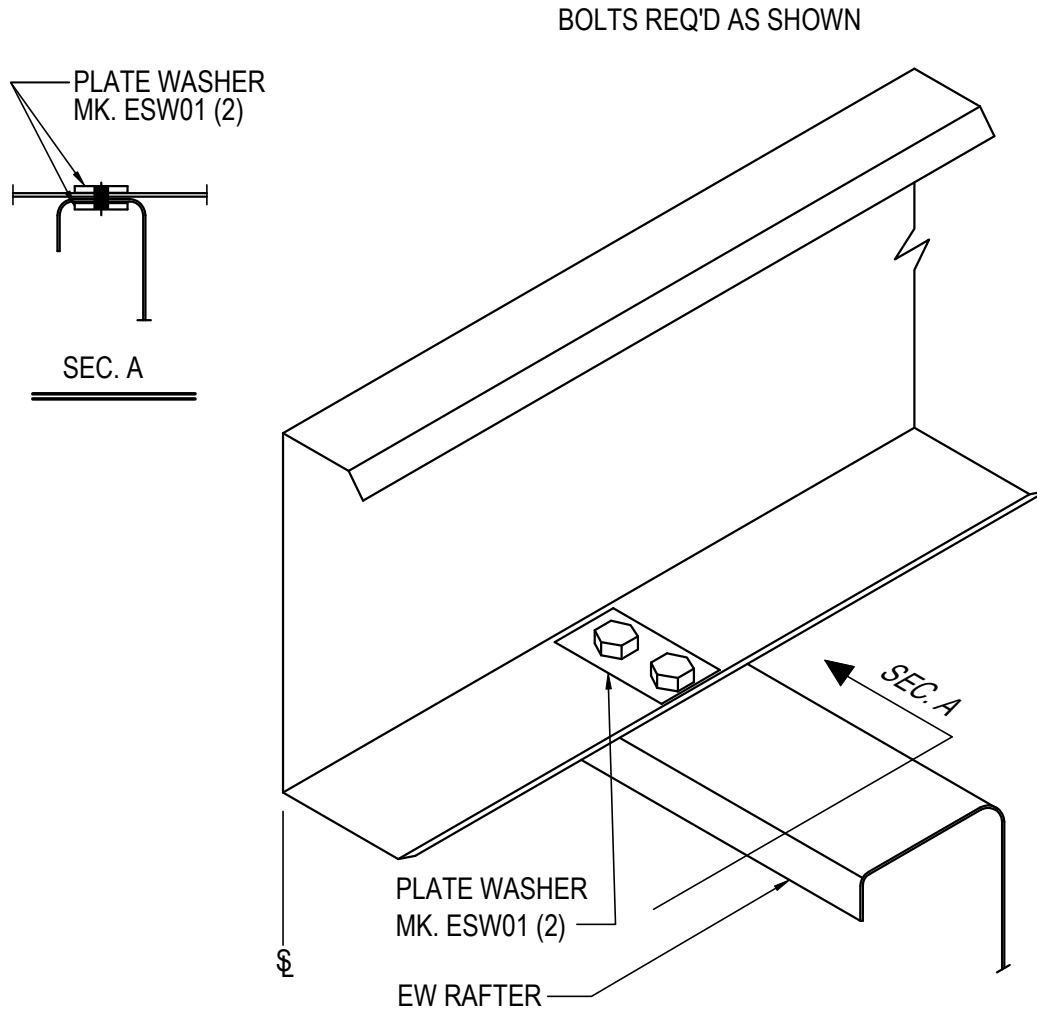

EAVE STRUT

LOW EAVE COLD-FORMED EW CONDITION
USE (2) 1/2" X 2" A325 BOLT H0603/ NUT H0300 U.N.O.
REFERENCE ERECTOR NOTE FOR TYP. WASHER REQUIREMENTS

BA0050

Detailer Notes:

- 1) N/A

BA0060 - LOW EAVE STRUT FLUSH/INSET WITH STRUT PLATE DETAIL

[Download the DWG file by clicking here.](#)

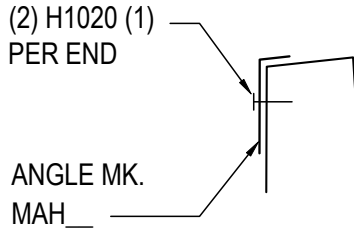

BOLTS REQ'D AS SHOWN

SEC. A

PART	ROOF SLOPE
MAH01	1:12
MAH02	2:12
MAH03	3:12
MAH04	4:12

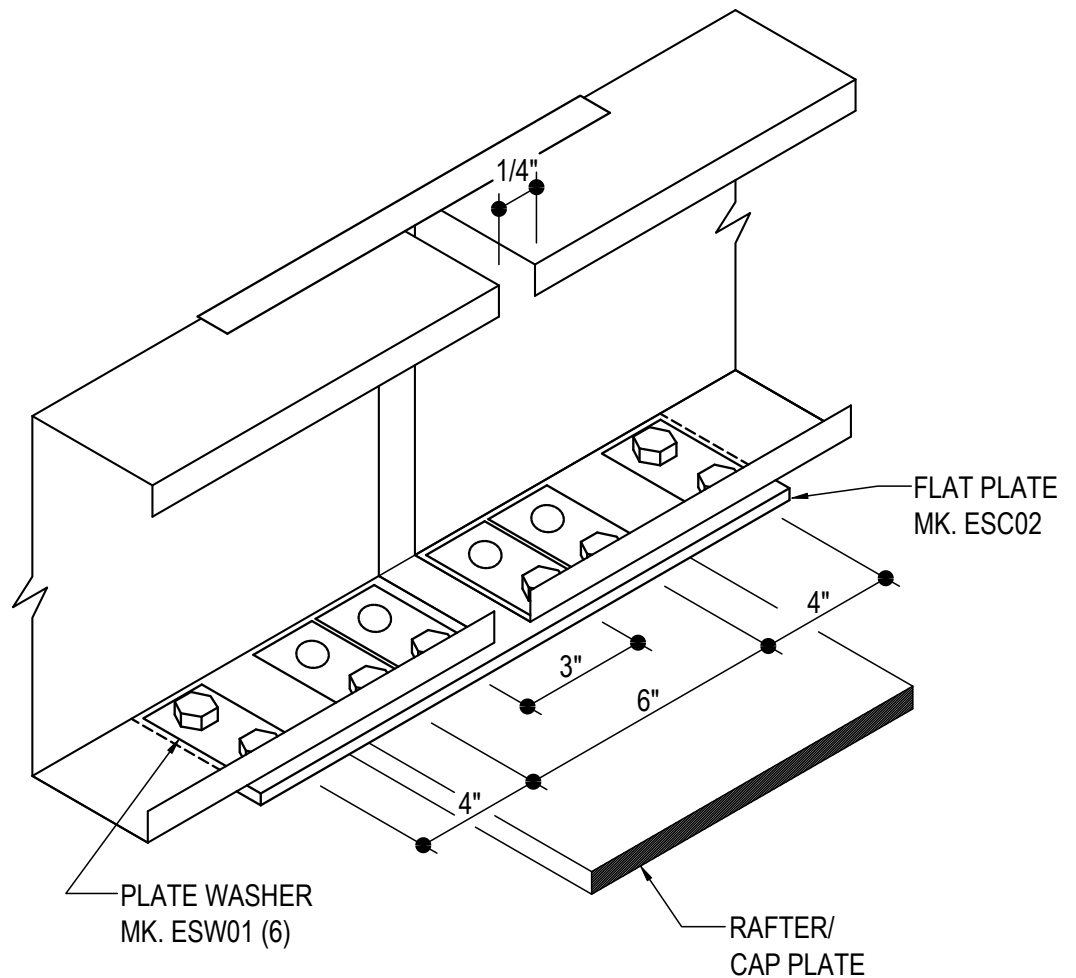

EAVE STRUT WITH STRUT PLATE

LOW EAVE FLUSH/INSET SW GIRT CONDITION
USE (8) 1/2" X 2" A325 BOLT H0603/ NUT H0300 U.N.O.

BA0060

Detailer Notes:

- 1) 8" MIN. CAP PLATE

BA0070 - LOW EAVE STRUT BYPASS SW GIRT WITH STRUT PLATE DETAIL

[Download the DWG file by clicking here.](#)

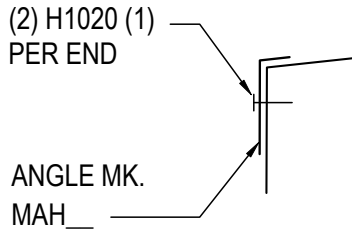

SEC. A

PART	ROOF SLOPE
MAH01	1:12
MAH02	2:12
MAH03	3:12
MAH04	4:12

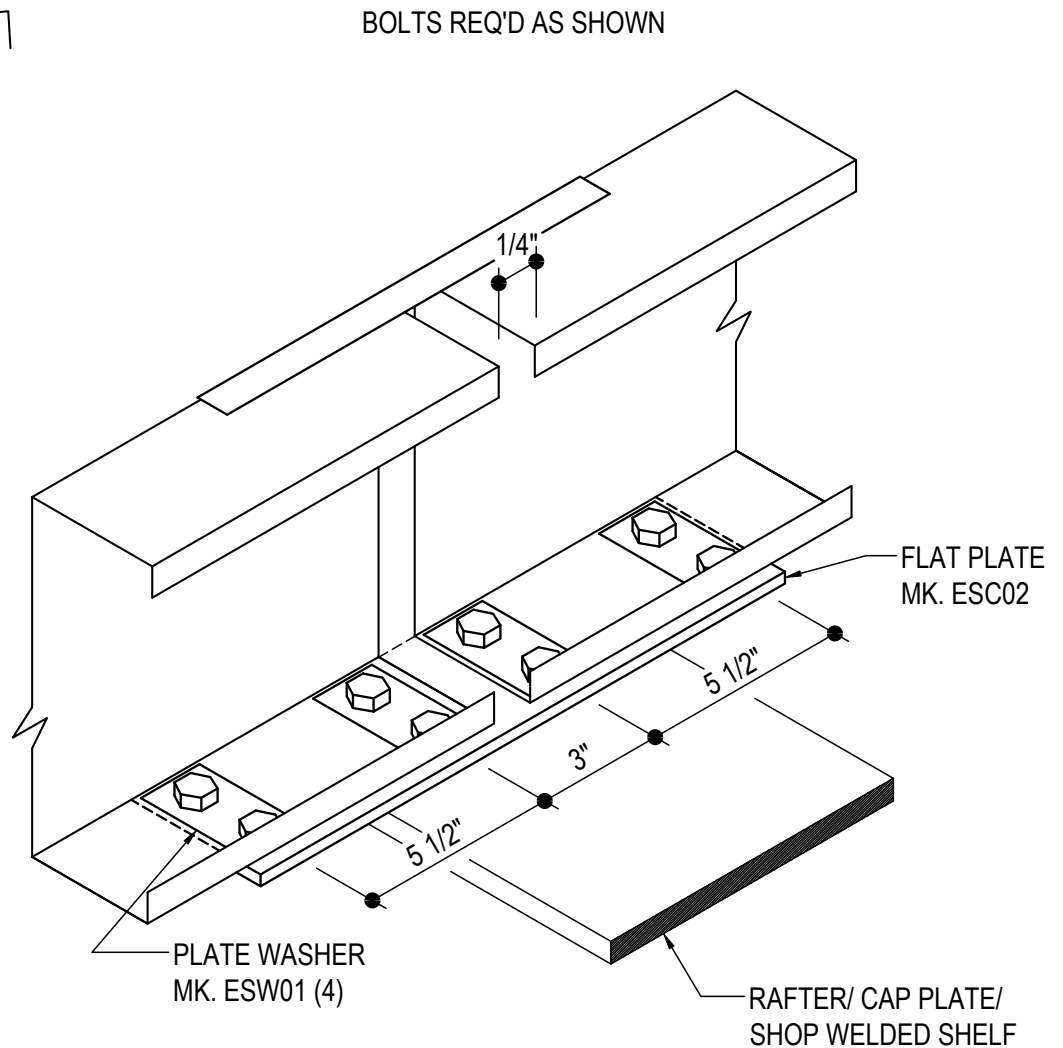

EAVE STRUT WITH STRUT PLATE

LOW EAVE BYPASS SW GIRT CONDITION
USE (8) 1/2" X 2" A325 BOLT H0603/NUT H0300 U.N.O.

BA0070

Detailer Notes:

1) N/A

BA0080 - LOW EAVE STRUT BYPASS SW GIRT AT ENDWALL FRAME DETAIL

[Download the DWG file by clicking here.](#)

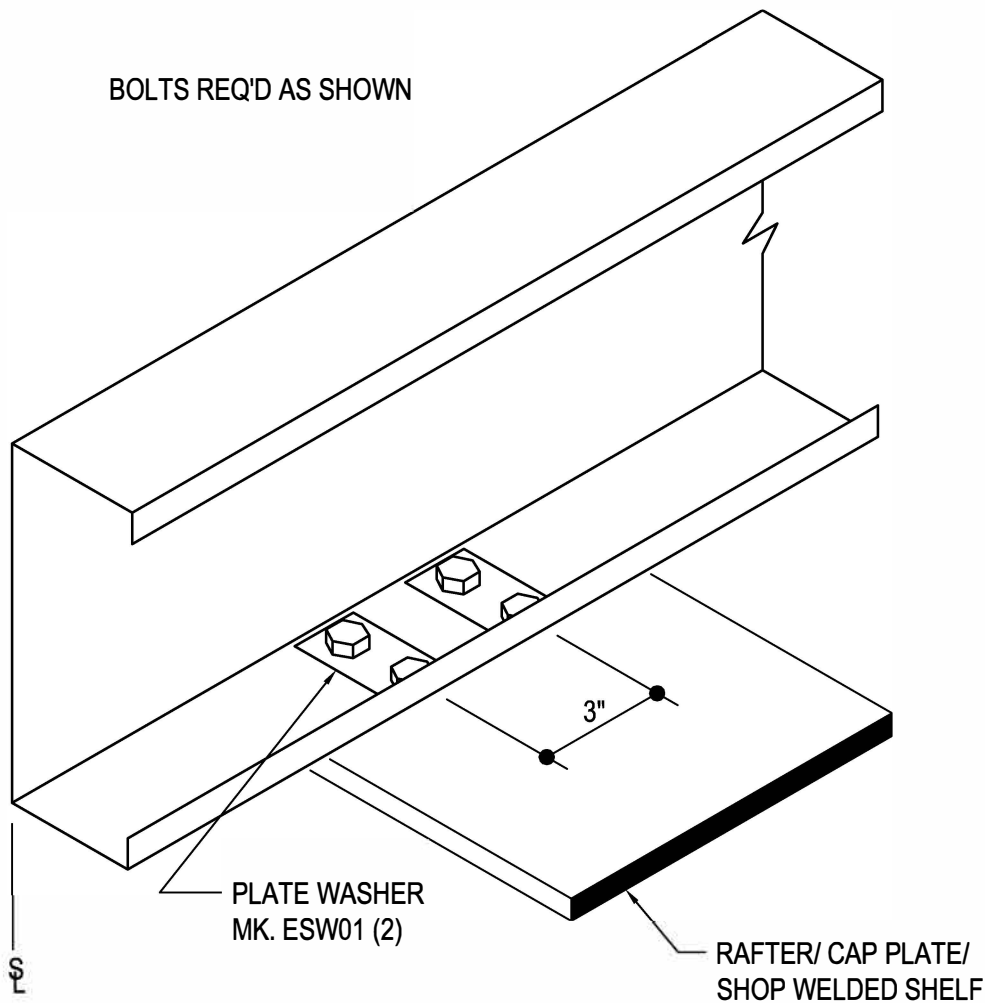

EAVE STRUT AT ENDWALL FRAME

LOW EAVE - BYPASS SW GIRT CONDITION
USE (4) 1/2" X 2" A325 BOLT H0603/NUT H0300 U.N.O.

BA0080

Detailer Notes:

- 1) N/A

BA0090 - LOW EAVE FLUSH/INSET SW GIRT AT RIGID FRAME ENDWALL DETAIL

[Download the DWG file by clicking here.](#)

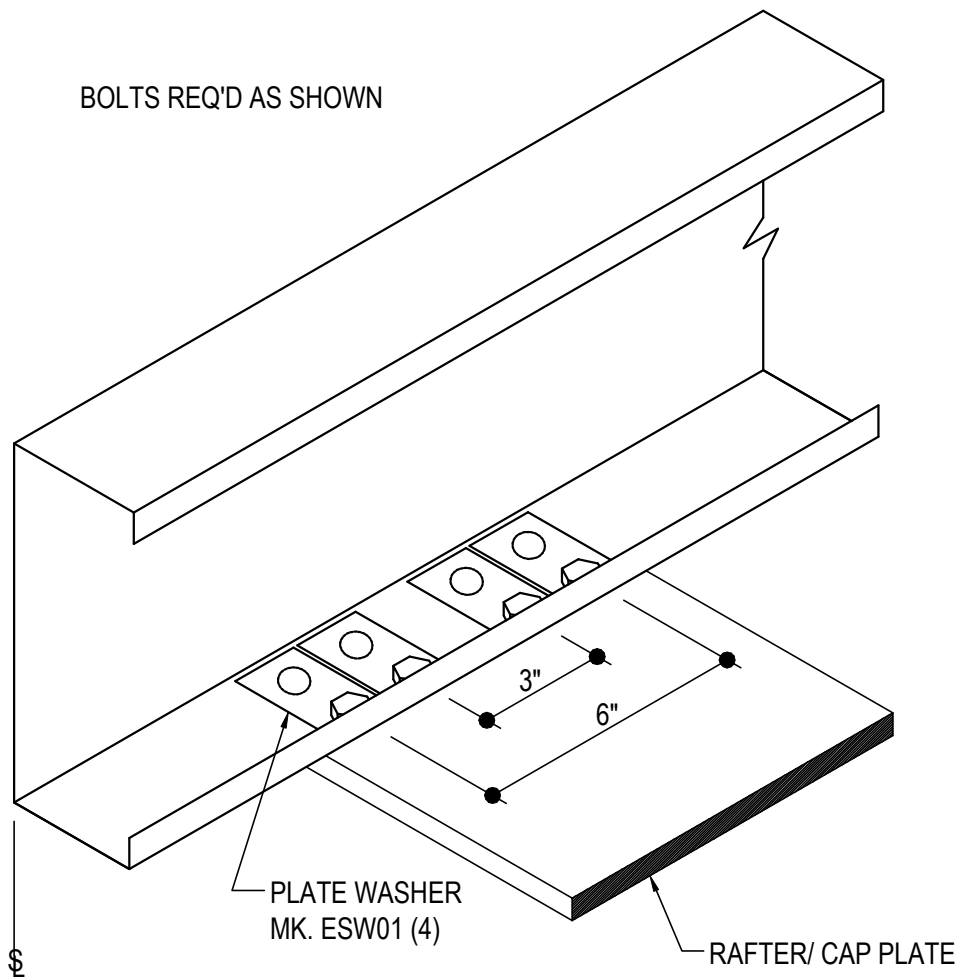

EAVE STRUT AT RIGID FRAME ENDWALL

LOW EAVE FLUSH/INSET SW GIRT CONDITION
USE (4) 1/2" X 2" A325 BOLT H0603/NUT H0300 U.N.O.

BA0090

Detailer Notes:

- 1) 8" MIN. CAP PLATE

BA0100 - LOW EAVE STRUT CF EW DETAIL

[Download the DWG file by clicking here.](#)

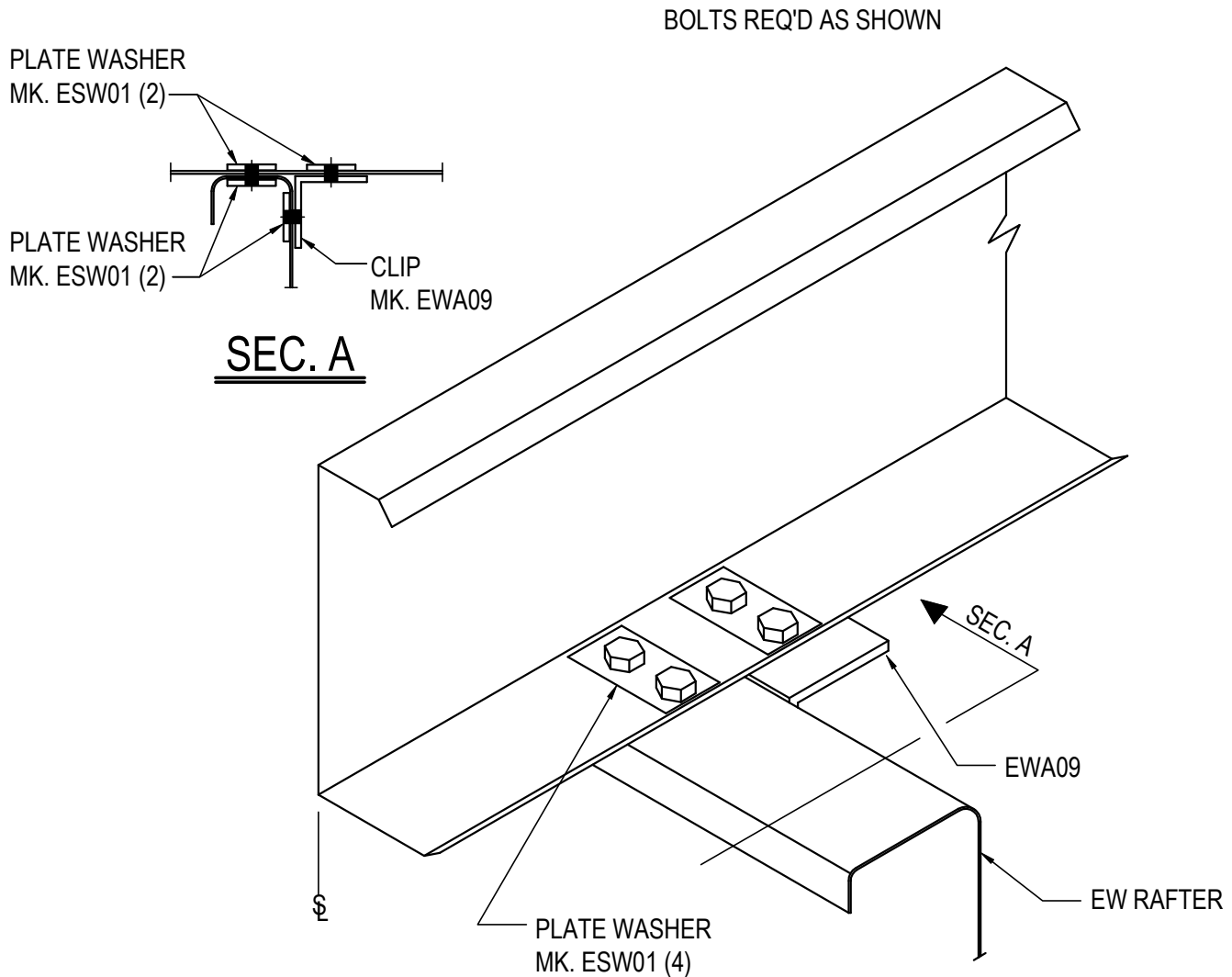

EAVE STRUT

LOW EAVE COLD-FORMED EW CONDITION
 USE (6) 1/2" X 2" A325 BOLT H0603/ NUT H0300 U.N.O.
 REFERENCE ERECTOR NOTE FOR TYP. WASHER REQUIREMENTS

BA0100

Detailer Notes:

1) N/A

BA0115 - LOW EAVE STRUT FLUSH/INSET AT COLUMN AND ROOF JOISTS DETAIL

[Download the DWG file by clicking here.](#)

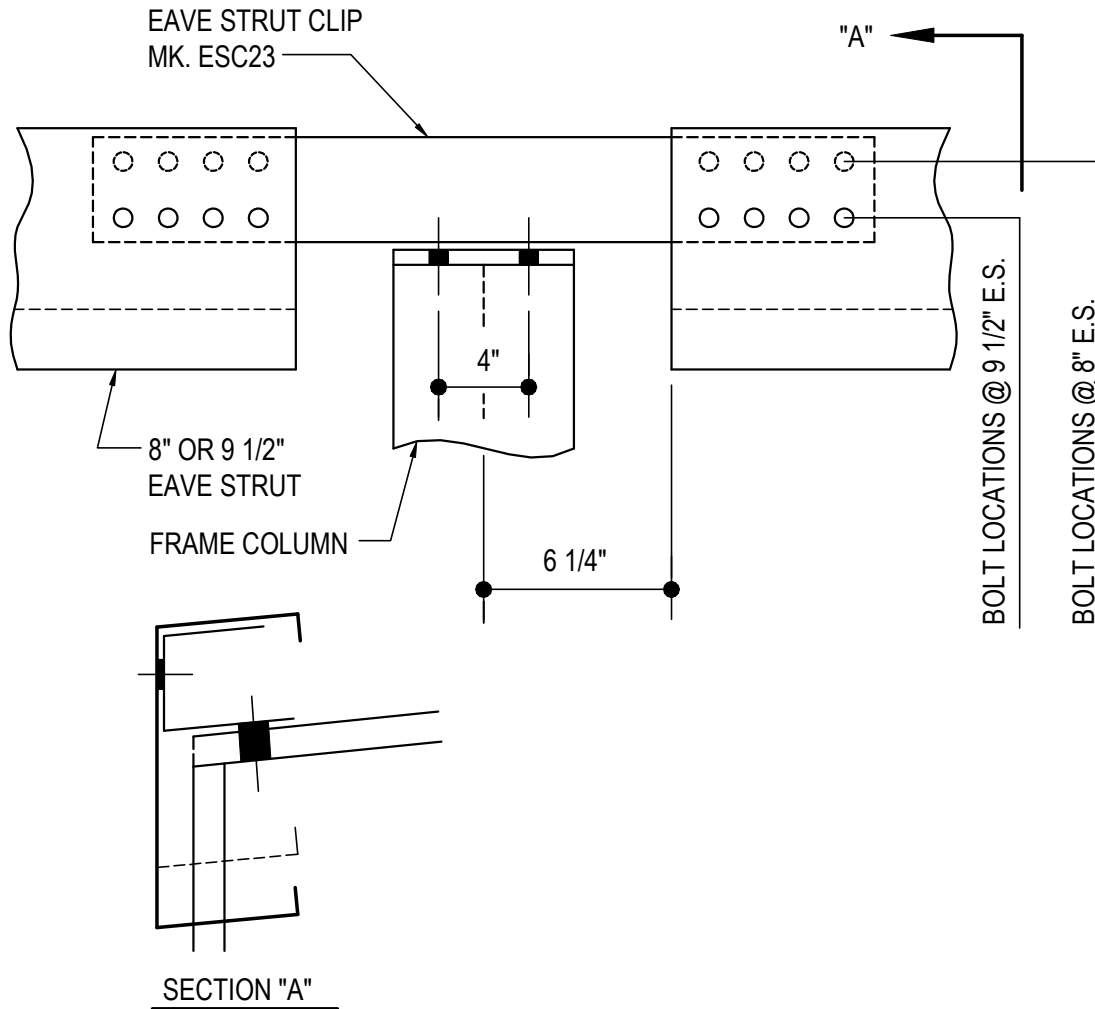

EQ LEG EAVE STRUT AT COL

LOW EAVE FLUSH/INSET SW GIRT, ROOF JOISTS
USE (10) 1/2" x 2" A325 BOLT H0603/NUT H0300 U.N.O.

BA0115

Detailer Notes:

- 1) N/A

BA0125 - LOW EAVE STRUT @ ENDWALL RAFTER WITH ROOF JOISTS DETAIL

[Download the DWG file by clicking here.](#)

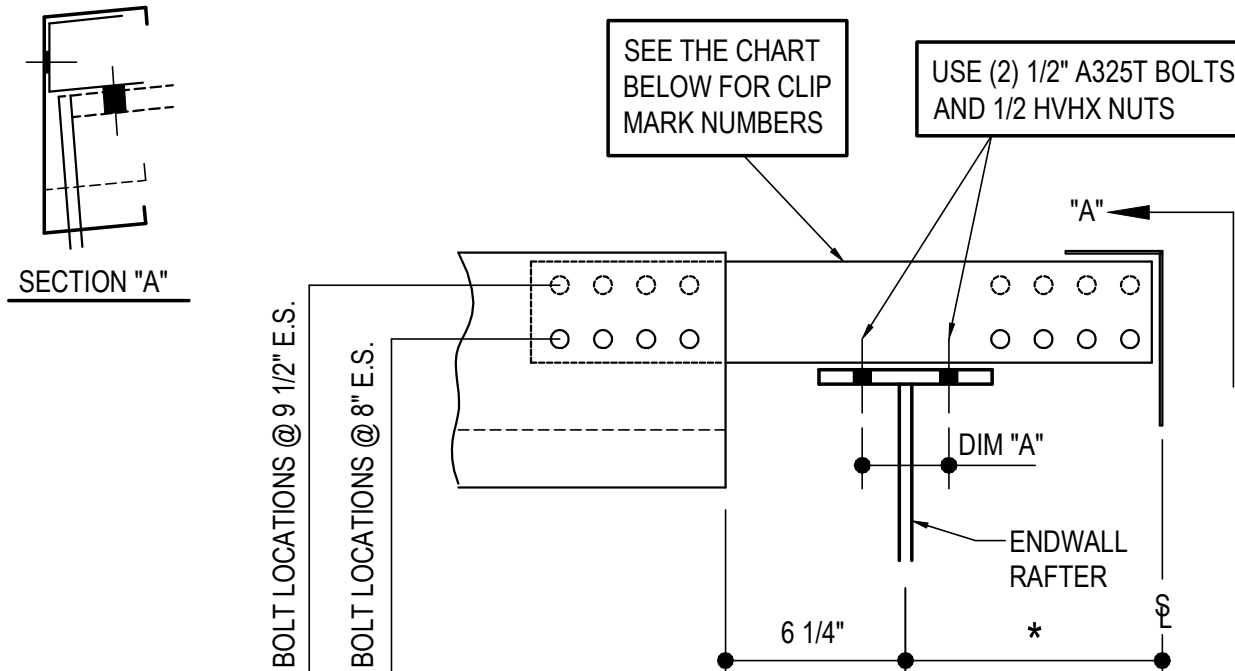

*	CONDITION	CLIP	DIM "A"
4"	FLUSH EW GIRTS	ESJ25	3"
5"	1" INSET EW GIRTS	ESJ26	3"
1'-0"	8" BYPASS EW GIRTS	ESJ27	3"
1'-1 1/2"	9 1/2" BYPASS EW GIRTS	ESJ28	3"
1'-4"	RIGID FRAME ENDWALL	ESC23	4"

EQ LEG EAVE STRUT-EW RAFTER

EAVE STRUT WITH ROOF JOIST AT LOW EAVE
USE (4) 1/2" x 2" A325 BOLT H0603/NUT H0300 U.N.O.

BA0125

Detailer Notes:

- 1) N/A

BA0140 - CEE PURLIN CONNECTION AT CANOPY

[Download the DWG file by clicking here.](#)

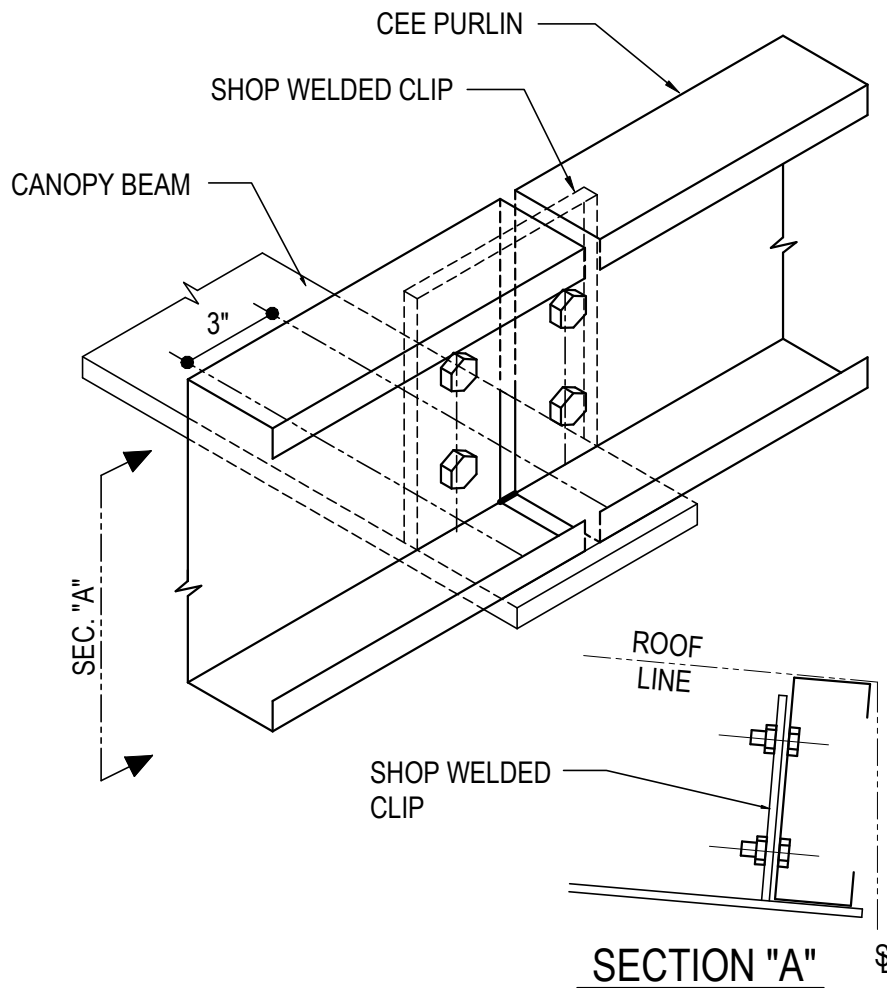

CEE PURLIN CONNECTION AT CANOPY

USE (4) 1/2" x 2" A325 BOLTS H0603/NUTS H0300
REFERENCE ERECTOR NOTE FOR TYP. WASHER REQUIREMENTS

BA0140

Detailer Notes:

- 1) N/A

BA0145 - CEE PURLIN TERMINATION AT CANOPY

[Download the DWG file by clicking here.](#)

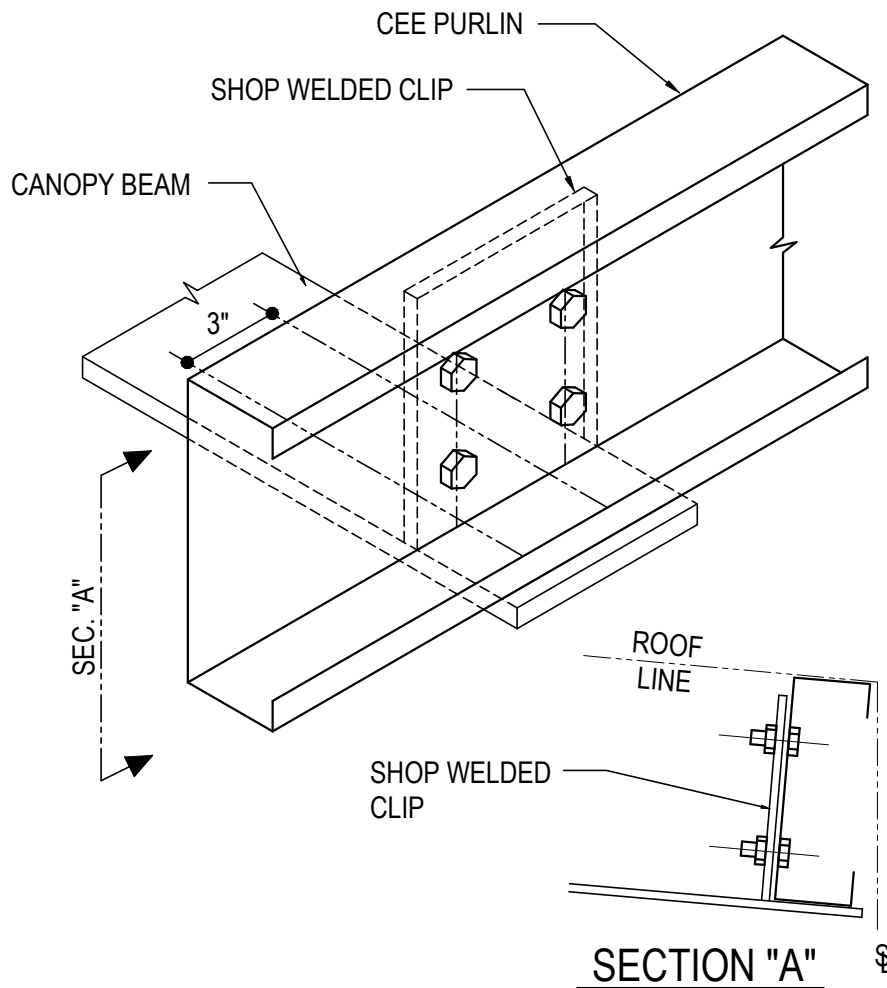

CEE PURLIN TERMINATION AT CANOPY

USE (4) 1/2" x 2" A325 BOLTS H0603/NUTS H0300

REFERENCE ERECTOR NOTE FOR TYP. WASHER REQUIREMENTS

BA0145

Detailer Notes:

- 1) N/A

BA0200 - EAVE STRUT AT STRUCTURAL EXPANSION DETAIL

[Download the DWG file by clicking here.](#)

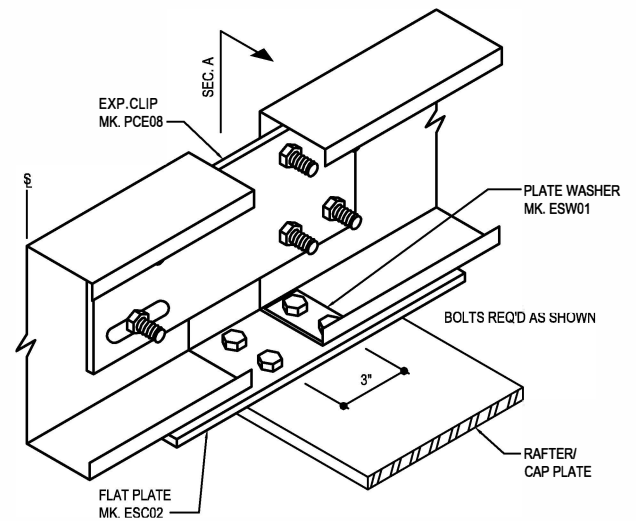
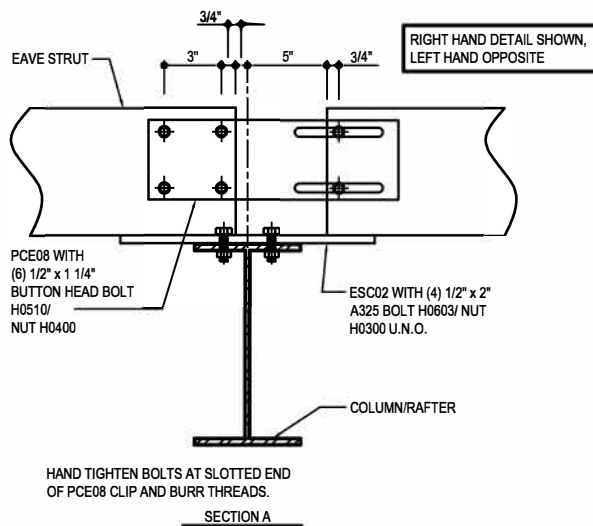

EAVE STRUT

STRUCTURAL EXPANSION JOINT AT EAVE STRUT

BA0200

Detailer Notes:

- 1) ONLY USE AT BYPASS SW

BA0340 - EAVE ANGLE ATTACHMENT - PURLIN

[Download the DWG file by clicking here.](#)

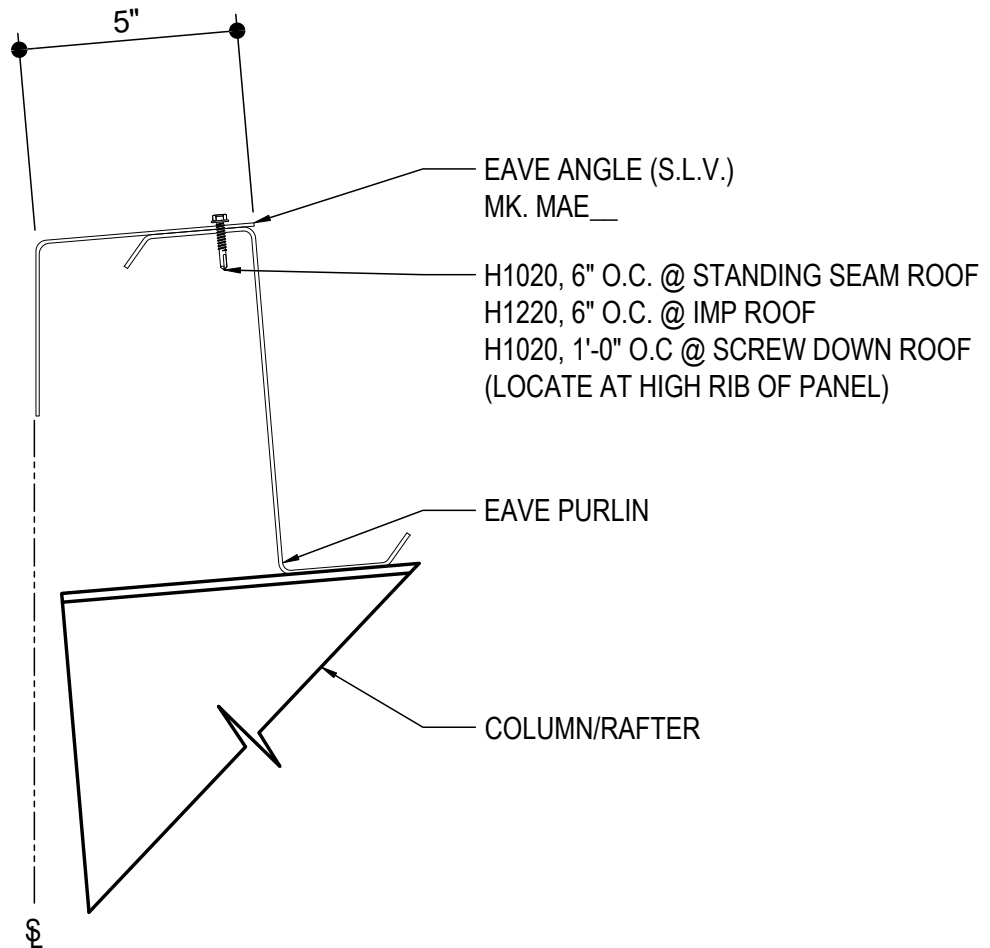

EAVE ANGLE

REVERSE PURLIN WITH EAVE ANGLE

BA0340

Detailer Notes:

1) N/A

BA0360 - EAVE ANGLE ATTACHMENT - JOIST

[Download the DWG file by clicking here.](#)

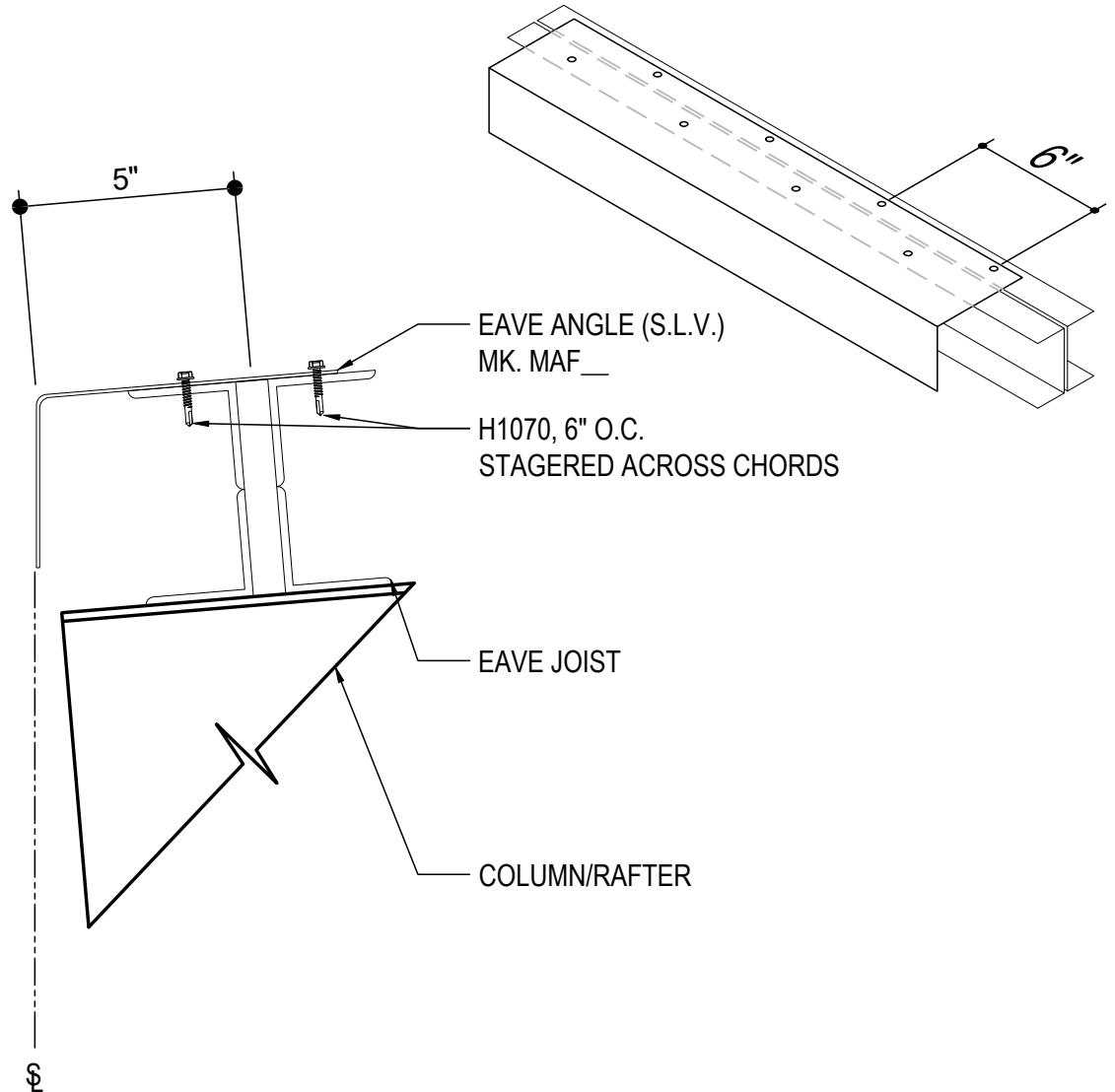

EAVE ANGLE

EAVE JOIST WITH EAVE ANGLE

BA0360

Detailer Notes:

1) N/A

BA2000 - EAVE ZEE MEMBER FOR R-Boost™

[Download the DWG file by clicking here.](#)

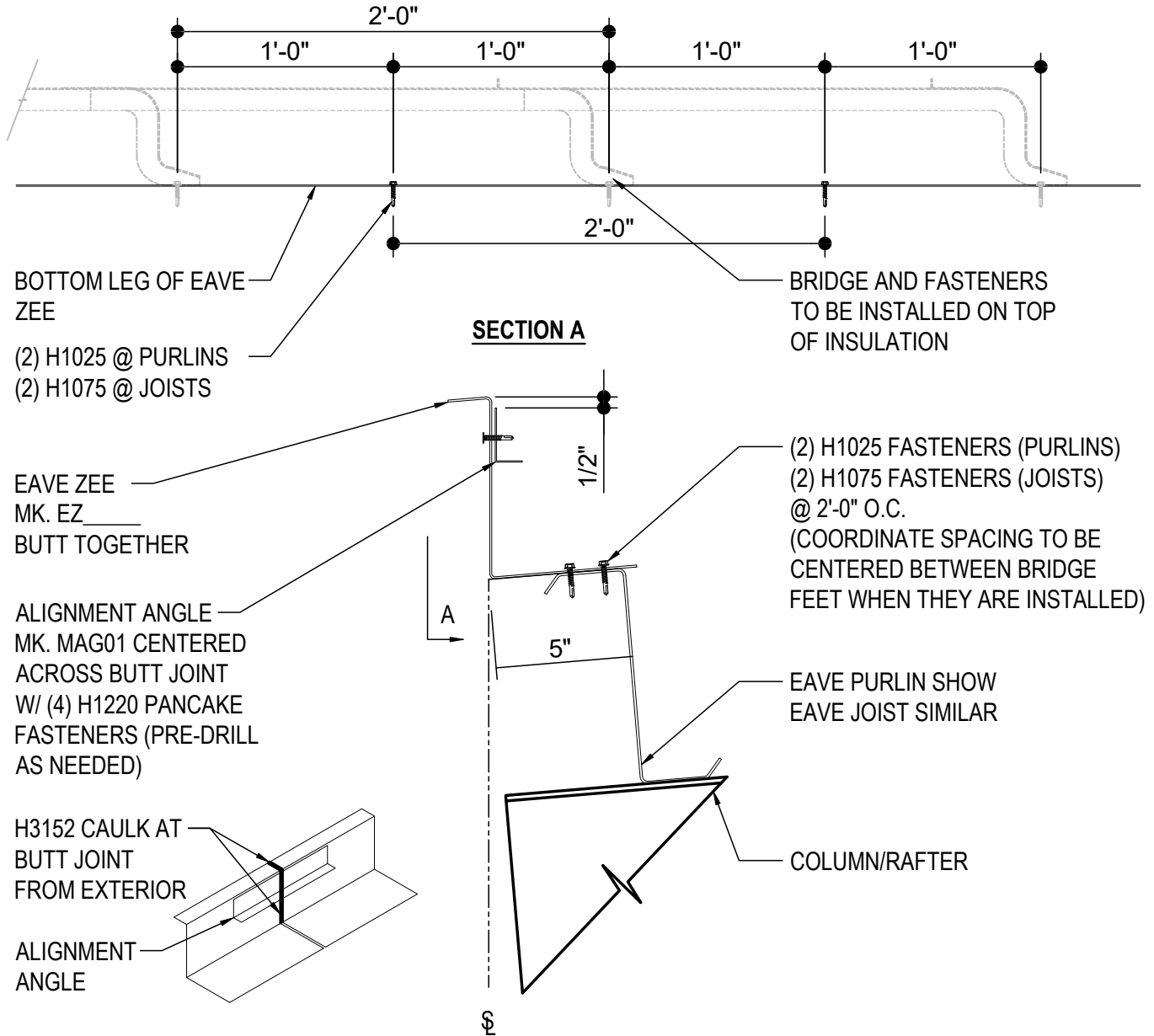

R-Boost™ EAVE ZEE

EAVE ZEE ATTACHMENT AT LOW EAVE

BA2000

Detailer Notes:

- 1) USE WITH EVERY PROJECT WITH R-Boost™ ROOF SYSTEMS. THE EAVE ZEE IS TO BE INSTALLED AT TIME OF PURLIN INSTALLATION.